

NB4N1158

Link Replicator for Fibre Channel, Gigabit Ethernet, HDTV and SATA

Up to 1.5 Gb/s

Description

The NB4N1158 is a high performance 3.3 V Serial Link Replicator which provides the function of serial loop replication and serial loopback control commonly required in Fibre Channel, GbE, HDTV and SATA applications. Other popular applications include Host Bus Adaptors for routing between internal and external connectors, and hot-pluggable links between redundant switch fabric cards.

IN is sent to both OUT0 and OUT1; each output is enabled by OE0 and OE1 when HIGH. OUT0 can select either IN or IN1 via the MUX0 pin. Likewise, OUT1 can select between IN or IN0 via the MUX1 pin. Out can select between IN0 and IN1.

In Link Replicator applications, such as the Line Card to Switch Card links, IN is transmitted to both OUT0 and OUT1 which either IN0 or IN1 is selected at OUT. In Host Adapter applications, IN goes to OUT0 (an internal connector) which returns data on IN0. IN0 is looped to OUT1 (an external connector) which returns data on IN1 and then back to the SerDes on OUT.

The NB4N1158 is packaged in a 4.7 mm x 9.7 mm TSSOP-28.

Features

- Replicates Fibre Channel, Gigabit Ethernet, HDTV, and Serial ATA (SATA) Links
- T11 Fibre Channel Complaint at 1.0625 Gb/s
- Differential LVPECL Outputs, External Load/Termination Resistors Required
- IEEE802.3z Gigabit Ethernet Compliant at 1.25 Gb/s
- SMPTE-292M Compliant at 1.485 Gb/s
- 330 mW Maximum Power Dissipation
- Operating Range: $V_{CC} = 3.135\text{ V to }3.465\text{ V}$
- 28-pin, 4.4 mm x 9.7 mm TSSOP Package
- These are Pb-Free Devices



ON Semiconductor®

<http://onsemi.com>

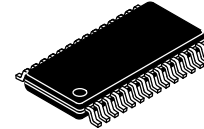

28 Lead TSSOP
DT SUFFIX
CASE 948A

MARKING DIAGRAM*

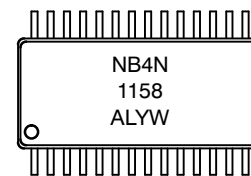

- A = Assembly Location
 - L = Wafer Lot
 - Y = Year
 - W = Work Week
 - G or ■ = Pb-Free Package
- (Note: Microdot may be in either location)

*For additional marking information, refer to Application Note AND8002/D.

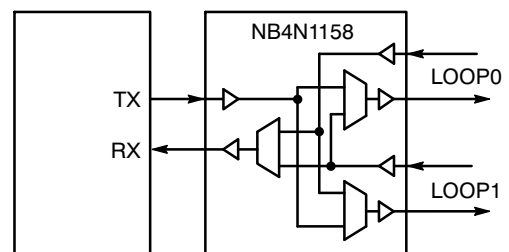

Figure 1. Simplified Application

ORDERING INFORMATION

See detailed ordering and shipping information in the package dimensions section on page 6 of this data sheet.

NB4N1158

TYPICAL APPLICATIONS CIRCUIT

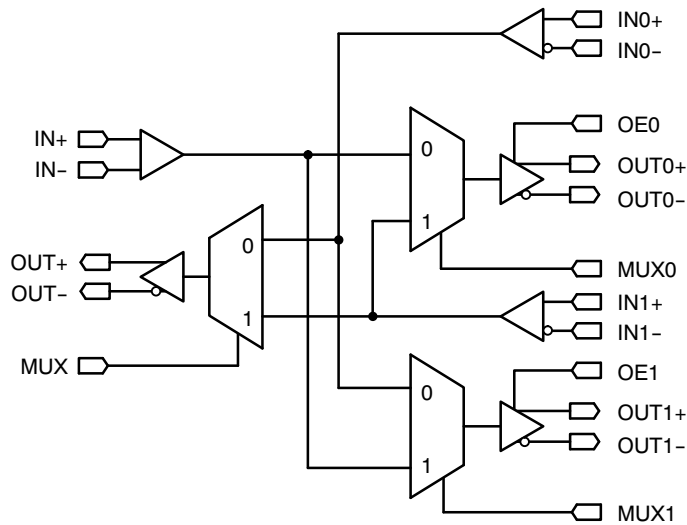

Figure 2. Simplified Block Diagram

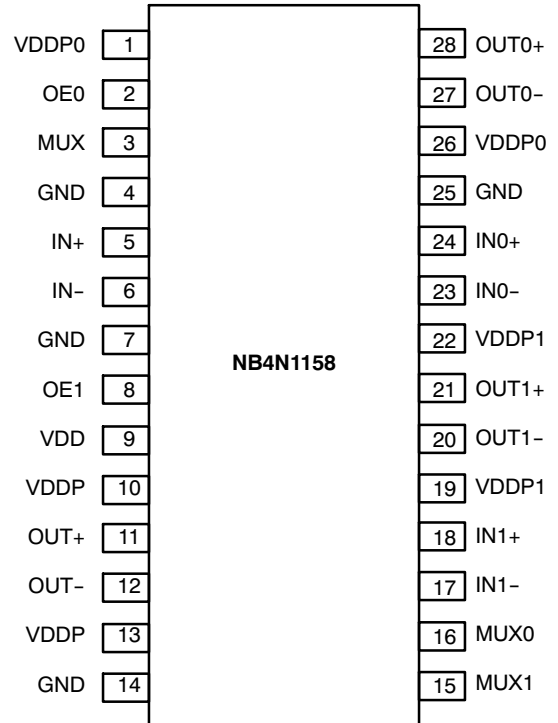

Figure 3. Pin Diagram for TSSOP-28

Table 1. OE, OUTPUT ENABLE FUNCTION

OEx*	Function
1	Outputs Enabled
0	Outputs Disabled OUTn+ = H, OUTn- = H

*Defaults to HIGH when left open

Table 2. PIN DESCRIPTION

Pin	Name	I/O	Description
5, 6 24, 23 18, 17	IN+, IN- IN0+, IN0- IN1+, IN1-	LVPECL Input LVPECL Input LVPECL Input	Non-inverted, Inverted, Differential Data Inputs internally biased to Approximately 1.2 V.
11, 12 28, 27 21, 20	OUT+, OUT- OUT0+, OUT0- OUT1+, OUT1-	LVPECL Output LVPECL Output LVPECL Output	Non-inverted, Inverted Differential Outputs. Typically terminated with 50 Ω resistor to V _{CC} - 2.0 V.
2 8	OE0 OE1	LVTTTL Input LVTTTL Input	OE0/OE1 enables OUT0/OUT1 when HIGH. When LOW, OUTx are powered down and both OUT+ and OUT- float HIGH.
3	MUX	LVTTTL Input	Selects Source for OUT, Selects Either IN0 (LOW) or IN1 (HIGH); defaults HIGH when left open.
15	MUX1	LVTTTL Input	Selects Source for OUT1. Selects Either IN (HIGH) or IN0 (LOW); defaults HIGH when left open.
16	MUX0	LVTTTL Input	Selects Source for OUT0. Selects either IN (LOW) or IN1 (HIGH); defaults HIGH when left open.
9	VDD	Power Supply	3.3 V Positive Supply Voltage for Digital Logic.
10, 13 1, 26 19, 22	VDDP VDDP0 VDDP1	Power Supply	3.3 V supply for LVPECL output drivers. VDDP is for OUT, VDDP0 is for OUT0, and VDDP1 is for OUT1.
4, 7, 14, 25	GND	Power Supply	Negative Supply Voltage, Connected to Ground

All VDD, VDDPx and GND Pins must be externally connected to appropriate power supply to guarantee proper operation.

NB4N1158

Table 3. ATTRIBUTES

Characteristics	Value
Internal Input Pullup Resistor	96 k Ω
ESD Protection	Human Body Model Machine Model
	> 1 kV > 100 V
Moisture Sensitivity (Note 1)	Level 3
Flammability Rating	Oxygen Index: 28 to 34
	UL 94 V-0 @ 0.125 in
Transistor Count	268 Devices
Meets or exceeds JEDEC Spec EIA/JESD78 IC Latchup Test	

1. For additional information, see Application Note AND8003/D.

Table 4. MAXIMUM RATINGS

Symbol	Parameter	Condition 1	Min	Max	Unit
V _{DD}	Positive Power Supply	GND = 0 V	0.5	4.0	V
V _{INP}	Input Voltage, PECL	GND = 0 V	-0.5	V _{DD} + 0.5	V
V _{INT}	Input Voltage, TTL	GND = 0 V	-0.5	V _{DD} + 0.5	V
I _{OUT}	Output HIGH current, PECL		-50	+50	mA
T _C	Case temperature under bias		-55	+125	°C
TA	Operating Temperature Range		-40	+85	°C
T _{stg}	Storage Temperature Range		-65	+150	°C
θ_{JA}	Thermal Resistance (Junction-to-Ambient)	0 lfpm 500 lfpm	TSSOP-28	76 60	°C/W °C/W
θ_{JC}	Thermal Resistance (Junction-to-Case)	(Note 2)	TSSOP-28	25	°C/W
T _{sol}	Wave Solder	Pb-Free		265	°C

Stresses exceeding Maximum Ratings may damage the device. Maximum Ratings are stress ratings only. Functional operation above the Recommended Operating Conditions is not implied. Extended exposure to stresses above the Recommended Operating Conditions may affect device reliability.

2. JEDEC standard multilayer board – 2S2P (2 signal, 2 power).

NB4N1158

Table 5. DC CHARACTERISTICS $V_{DD} = 3.30\text{ V} \pm 5\%$, $GND = 0\text{ V}$; $T_A = -40^\circ\text{C}$ to $+85^\circ\text{C}$ (Note 3)

Symbol	Characteristic	Min	Typ	Max	Unit
V_{DD}	Power Supply Voltage, $3.30\text{ V} \pm 5\%$	3.14		3.47	V
I_{DD}	Power Supply Current (Outputs open)		57	75	mA
P_D	Power Dissipation; Outputs Open; $V_{DD} = V_{DDmax}$			330	mW
ΔV_{IN}	Receiver Differential Voltage Amplitude; (IN, IN0, IN1), AC-Coupled, Internally Biased to 1.2 V; Differential Measurement - ($V_{INn+} - V_{INn-}$)	300		2600	mV
ΔV_{OUT50}	Output Differential Voltage Swing, peak-peak; (OUT, OUT0, OUT1) Outputs loaded / terminated with $50\ \Omega$ to $V_{DD} - 2.0\text{ V}$ Differential Measurement - ($V_{OUTn+} - V_{OUTn-}$)	1000	1600	2200	mV
ΔV_{OUT75}	Output Differential Voltage Swing, peak-peak; (OUT, OUT0, OUT1) Outputs loaded / terminated with $75\ \Omega$ to $V_{DD} - 2.0\text{ V}$ Differential Measurement - ($V_{OUTn+} - V_{OUTn-}$)	1200	1650	2200	mV

LVC MOS/LVTTL INPUTS

V_{IH}	Input HIGH Voltage, TTL	2.0		$V_{DD} + 0.5$	V
V_{IL}	Input LOW Voltage, TTL	0		0.8	V
I_{IH}	Input HIGH Current, TTL; $V_{IN} = 2.4\text{ V}$			100	μA
I_{IL}	Input LOW Current, TTL; $V_{IN} = 0.5\text{ V}$	-100			μA

NOTE: Device will meet the specifications after thermal equilibrium has been established when mounted in a test socket or printed circuit board with maintained transverse airflow greater than 500 lfm. Electrical parameters are guaranteed only over the declared operating temperature range. Functional operation of the device exceeding these conditions is not implied. Device specification limit values are applied individually under normal operating conditions and not valid simultaneously.

3. LVPECL outputs loaded with external $50\ \Omega$ termination resistors to $V_{TT} = V_{DD} - 2.0\text{ V}$ for proper operation (see Figure 6).

Table 6. AC CHARACTERISTICS $V_{DD} = 3.3\text{ V} \pm 5\%$, $GND = 0\text{ V}$ -40°C to $+85^\circ\text{C}$

Symbol	Characteristic	Min	Typ	Max	Unit
$f_{IN/OUT}$	Input / Output Frequency Range	1.0		1.5	Gb/s
t_r/t_f	Output rise and Fall Times (Note 4)		110	150	ps
t_{PD}	Propagation Delay, IN to OUT		0.375	4.0	ns
T_{DJ}	Deterministic Jitter Added to Serial Input Up to 1.5 Gb/s; K28.5 \pm Pattern			40	ps pk-pk

NOTE: Device will meet the specifications after thermal equilibrium has been established when mounted in a test socket or printed circuit board with maintained transverse airflow greater than 500 lfm. Electrical parameters are guaranteed only over the declared operating temperature range. Functional operation of the device exceeding these conditions is not implied. Device specification limit values are applied individually under normal operating conditions and not valid simultaneously.

4. Measured 20% to 80%

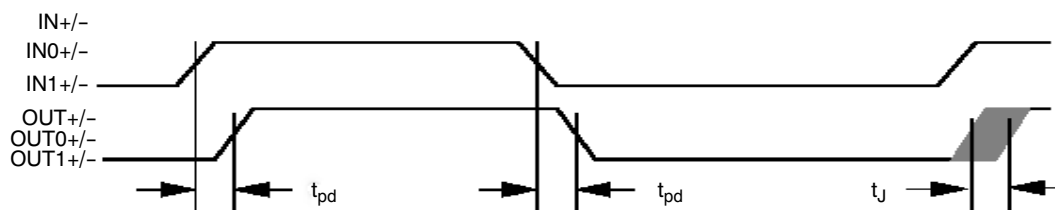

Figure 4. Timing Waveforms

NB4N1158

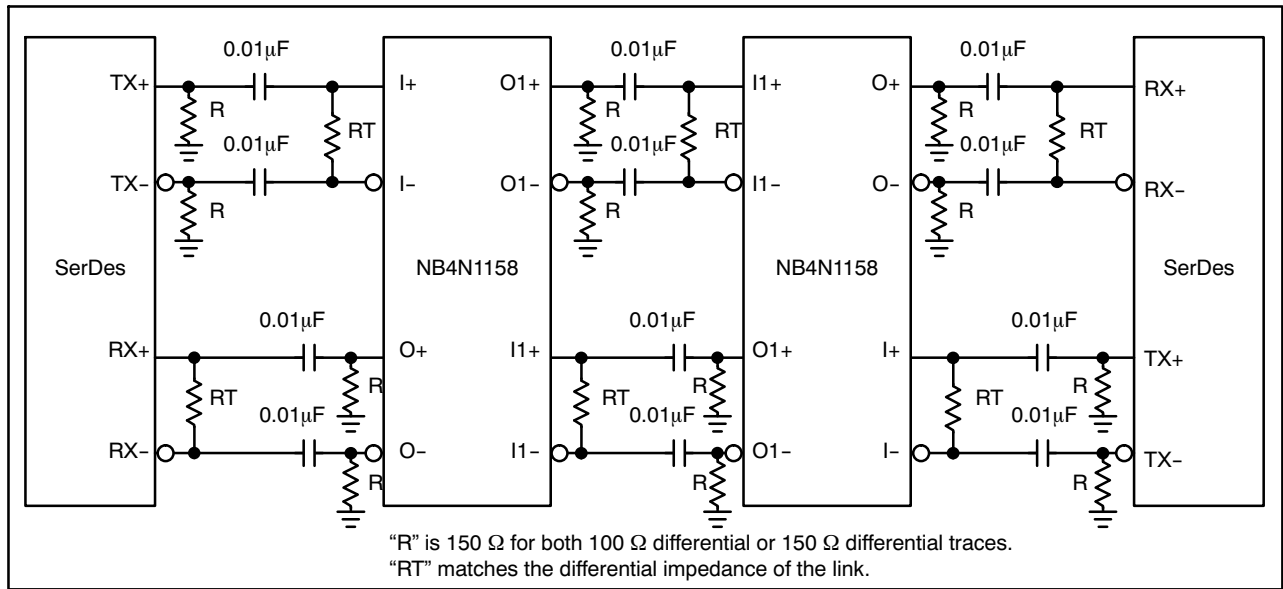

Figure 5. NB4N1158 Application Interface Example

IN+/IN- Input Functionality

The differential inputs are internally biased to ~ 1.2 V. In a typical application, the differential inputs are capacitor-coupled and will swing symmetrically above and below 1.2 V, preserving a 50% duty cycle to the outputs.

With this technique, the NB4N1158 will accept any differential input allowing for LVPECL, CML, LVDS, and HSTL input levels.

OUT+ / OUT- Outputs

The differential output buffers of the NB4N1158 utilize standard Positive Emitter Coupled Logic (PECL) architecture for OUT+ and OUT-. The outputs are designed to drive differential transmission lines with nominally 50 Ω or 75 Ω characteristic impedance. External DC load/termination with a 50 Ω resistor to $V_{TT} = V_{DD} - 2.0$ V is required. See Figure 6 for output termination scheme.

OEx Output Enable

The NB4N1158 incorporates output enable pins, OE0 and OE1, that work by powering down the output buffer and associated driving circuitry. Using this approach results in both differential outputs going HIGH, and a reduction in I_{DD} current of approx. 29 mA for each disabled output pair.

When OEx is LOW, outputs are disabled, OUTx+ and OUTx- are set HIGH.

Power Supply Bypass information

A clean power supply will optimize the performance of the device. The NB4N1158 provides separate power supply pins for the digital circuitry (V_{DD}) and LVPECL outputs (V_{DDPn}). Placing a bypass capacitor of 0.01 μ F to 0.1 μ F on each V_{DD} pin will help ensure a noise free V_{DD} power supply. The purpose of this design technique is to try and isolate the high switching noise of the digital outputs from the relatively sensitive digital core logic.

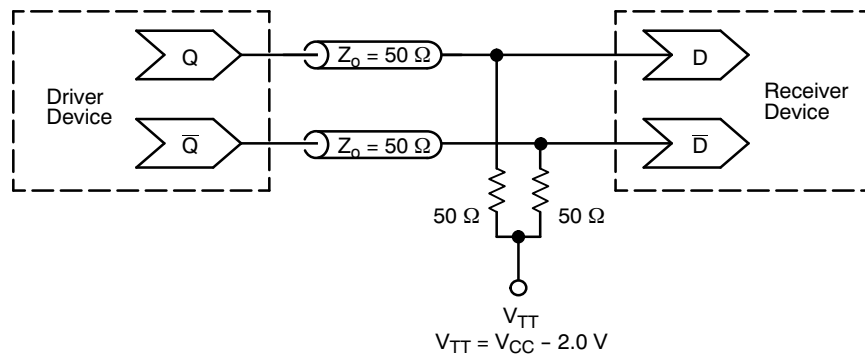

Figure 6. Typical Termination for Output Driver and Device Evaluation (See Application Note AND8020/D – Termination of ECL Logic Devices.)

NB4N1158

Resource Reference of Application Notes

- AND8002 - Marking and Date Codes
- AND8009 - ECLinPS Plus Spice I/O Model Kit
- AND8020 - Termination of ECL Logic Devices

ORDERING INFORMATION

Device	Package	Shipping [†]
NB4N1158DTG	TSSOP-28 (Pb-Free)	50 Units / Rail
NB4N1158DTR2G	TSSOP-28 (Pb-Free)	2500 / Tape & Reel

[†]For information on tape and reel specifications, including part orientation and tape sizes, please refer to our Tape and Reel Packaging Specifications Brochure, BRD8011/D.

NB4N1158

PACKAGE DIMENSIONS

28 LEAD TSSOP
DT SUFFIX
CASE 948AA-01
ISSUE O

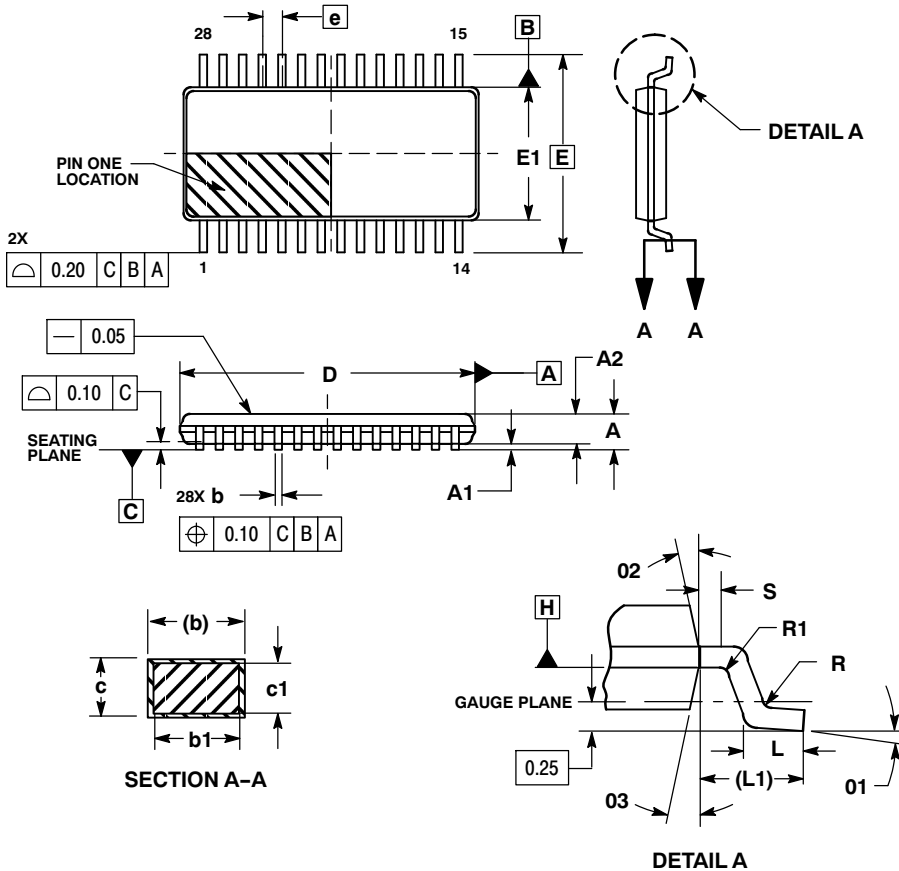

NOTES:

1. DIMENSIONS AND TOLERANCING PER ASME Y14.5M, 1994.
2. DIMENSIONS IN MILLIMETERS.
3. DIMENSION b DOES NOT INCLUDE DAMBAR PROTRUSION. ALLOWABLE DAMBAR PROTRUSION SHALL BE 0.08 MM TOTAL IN EXCESS OF THE " b " DIMENSION AT MAXIMUM MATERIAL CONDITION.
4. DATUMS A AND B TO BE DETERMINED AT DATUM PLANE H.

MILLIMETERS		
DIM	MIN	MAX
A	---	1.20
A1	0.05	0.15
A2	0.80	1.05
b	0.19	0.30
b1	0.19	0.25
c	0.09	0.20
c1	0.09	0.16
D	9.60	9.80
E	6.40 BSC	
E1	4.30	4.50
e	0.65 BSC	
L	0.45	0.75
L1	1.00 REF	
R	0.09	---
R1	0.09	---
S	0.20	---
01	0°	8°
02	12° REF	
03	12° REF	

ON Semiconductor and **ON** are registered trademarks of Semiconductor Components Industries, LLC (SCILLC). SCILLC reserves the right to make changes without further notice to any products herein. SCILLC makes no warranty, representation or guarantee regarding the suitability of its products for any particular purpose, nor does SCILLC assume any liability arising out of the application or use of any product or circuit, and specifically disclaims any and all liability, including without limitation special, consequential or incidental damages. "Typical" parameters which may be provided in SCILLC data sheets and/or specifications can and do vary in different applications and actual performance may vary over time. All operating parameters, including "Typicals" must be validated for each customer application by customer's technical experts. SCILLC does not convey any license under its patent rights nor the rights of others. SCILLC products are not designed, intended, or authorized for use as components in systems intended for surgical implant into the body, or other applications intended to support or sustain life, or for any other application in which the failure of the SCILLC product could create a situation where personal injury or death may occur. Should Buyer purchase or use SCILLC products for any such unintended or unauthorized application, Buyer shall indemnify and hold SCILLC and its officers, employees, subsidiaries, affiliates, and distributors harmless against all claims, costs, damages, and expenses, and reasonable attorney fees arising out of, directly or indirectly, any claim of personal injury or death associated with such unintended or unauthorized use, even if such claim alleges that SCILLC was negligent regarding the design or manufacture of the part. SCILLC is an Equal Opportunity/Affirmative Action Employer. This literature is subject to all applicable copyright laws and is not for resale in any manner.

PUBLICATION ORDERING INFORMATION

LITERATURE FULFILLMENT:

Literature Distribution Center for ON Semiconductor
P.O. Box 5163, Denver, Colorado 80217 USA
Phone: 303-675-2175 or 800-344-3860 Toll Free USA/Canada
Fax: 303-675-2176 or 800-344-3867 Toll Free USA/Canada
Email: orderlit@onsemi.com

N. American Technical Support: 800-282-9855 Toll Free
USA/Canada
Europe, Middle East and Africa Technical Support:
Phone: 421 33 790 2910
Japan Customer Focus Center
Phone: 81-3-5773-3850

ON Semiconductor Website: www.onsemi.com

Order Literature: <http://www.onsemi.com/orderlit>

For additional information, please contact your local Sales Representative

